

Martin Mounting and Adjusting Procedure Variable Pitch Sheaves

Single Groove Sheaves Without External Key:

Mounting:

1. Make sure that the shaft, sheave bore, key and keyway are free of burrs and paint.
2. All sheaves should be mounted on the motor or driving shaft with the end containing the setscrew "R" toward the motor. Be sure setscrew "R" is well over the shaft.
3. Fit shaft key "C" between sheave and shaft. Lock setscrew "R" in place. Wrench torque 110 in.-lb. minimum – 130 in.-lb. maximum.
4. Be sure both driving and driven sheaves are in alignment and that shafts are parallel.
5. Total axial and parallel misalignment must not exceed $\frac{1}{4}^\circ$.

Adjusting:

1. Loosen setscrew "V" in movable flange of sheave.
2. Adjust sheave pitch diameter for desired speed by opening rotating parts by half or full turn increments from closed position. **Do not open more than five full turns for "A" belts or six full turns for "B" belts.**
3. Tighten setscrew "V" over a flat in the hub to 110 to 130 in.-lb.
4. Put on belts and adjust belt tension. (Do not force belts over grooves.)
5. Future adjustments should be made by loosening the belt tension and increasing or decreasing the pitch diameter of the sheave by half or full turns as required. Readjust belt tension before starting drive.
6. Be sure that key is in place and that all setscrews are torqued properly before starting drive. Check setscrews and belt tension after 24 hours of service.

Do not operate sheave with flange projecting beyond the hub end.

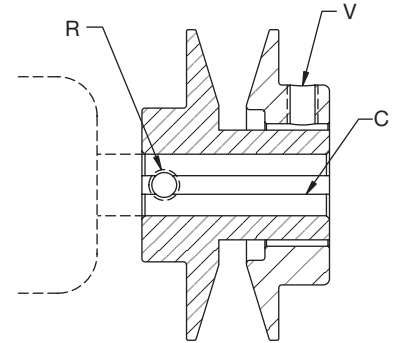

Single Groove Sheaves With External Key:

Key "H" projects to provide a grip for removal.

Do not operate sheave with flange projecting beyond the hub end.

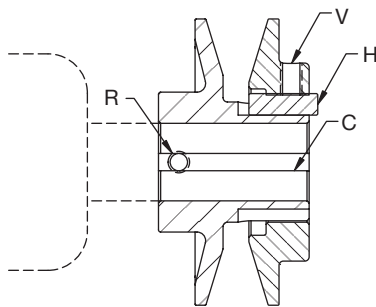

Mounting:

1. Make sure that the shaft, sheave bore, keys and keyways are free of burrs and paint.
2. All sheaves should be mounted on the motor or driving shaft with the end containing the setscrew "R" toward the motor. Be sure setscrew "R" is well over the shaft.
3. Fit shaft key "C" between sheave and shaft. Lock setscrew "R" in place. Wrench torque 110 in.-lb. minimum - 130 in.-lb. maximum.
4. Be sure both driving and driven sheaves are in alignment and that shafts are parallel.
5. Total axial and parallel misalignment must not exceed $\frac{1}{4}^\circ$.

Adjusting:

1. Loosen setscrew "V" in movable flange of sheave and pull out external key "H". (This key projects a small amount to provide a grip for removal.)
2. Adjust sheave pitch diameter for desired speed by opening rotating parts by half or full turn increments from closed position. **Do not open more than five full turns for "A" belts or six full turns for "B" belts. (Except 1VP34 - 5 turns.)**
3. Replace key "H" and tighten setscrew "V" to 110 to 130 in.-lb.
4. Put on belts and adjust belt tension. (Do not force belts over grooves.)
5. Future adjustments should be made by loosening the belt tension and increasing or decreasing the pitch diameter of the sheave by half or full turns as required. Readjust belt tension before starting drive.
6. Be sure that all keys are in place and that all setscrews are torqued properly before starting drive. Check setscrews and belt tension after 24 hours service.

WARNING: Because of the possible danger to person(s) or property from accidents which may result from the improper use of products, it is important that correct procedures be followed: Products must be used in accordance with the engineering information specified in the catalog. Proper installation, maintenance and operation procedures must be observed. The instructions given above must be followed. Inspections should be made as necessary to assure safe operation under prevailing conditions. All rotating power transmission products when used in a drive are potentially dangerous and must be guarded by the user as required by applicable laws, regulations, standards, and good safety practice. (Refer to ANSI Standard B15.1.)

Martin Mounting and Adjusting Procedure

Variable Pitch Sheaves

Double Groove Sheaves With External Key:

Mounting:

1. Make sure that the shaft, sheave bore, keys and keyways are free of burrs and paint.
2. Remove key "H" from sheave. Unscrew flanges until setscrew "R" is visible. If setscrew "R" is at an angle, flange may have to be removed in order to tighten it.
3. All sheaves should be mounted on the motor or driving shaft with the end containing the setscrew "R" toward the motor. If setscrew "R" is at an angle, mount away from motor.
4. Fit shaft key "C" between sheave and shaft, and lock setscrew "R" in place. Wrench torque 110 in.-lb. minimum - 130 in.-lb. maximum. Replace outboard flange.
5. Be sure the center flange of both the driving and driven sheaves are in alignment and shafts are parallel.
6. Total axial and parallel misalignment must not exceed $\frac{1}{4}^\circ$.

Adjusting:

Each flange of the sheave has a small notch on the O.D. of the flange. This mark is located directly over the keyway on the two adjustable flanges and over one of the keyways on the non-adjustable (center) flange. To obtain proper adjustments:

1. Loosen setscrews "V" in moving flanges and pull out key "H". (This key projects a small amount to provide a grip for removal.)
2. Rotate both movable flanges inward until they touch the center flange.
3. Locate the notch over the keyway on the center flange.
4. Open each movable flange until its notch is adjacent to the notch on the center flange. Be certain that neither movable flange is opened more than one full turn.
5. From the position obtained in Step 4, open each movable flange the same number of full or half turns until the desired number of turns is obtained. **Do not open more than five full turns for "A" belts or six full turns for "B" belts. (Except 2VP36 - 5 turns.)**
6. Replace key "H" and tighten setscrews "V". Wrench torque 110 in.-lb. minimum to 130 in.-lb. maximum.
7. Put on belts and adjust belt tension. (Do not force belts over flanges.)
8. Future adjustments should be made by loosening the belt tension and increasing or decreasing the pitch diameter of the sheave by half or full turns as required. Readjust belt tension before starting drive.
9. Two groove sheaves must have both halves adjusted by the same number of turns from the position established in Step 4 to ensure the same pitch diameter.
10. Be sure that all keys are in place and that all setscrews are torqued properly before starting drive. Check setscrews and belt tension after 24 hours service.

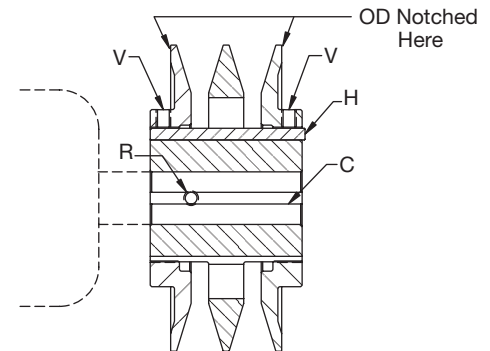

Key "H" projects to provide a grip for removal.

Do not operate sheave with flange projecting beyond the hub end.

WARNING: Because of the possible danger to person(s) or property from accidents which may result from the improper use of products, it is important that correct procedures be followed: Products must be used in accordance with the engineering information specified in the catalog. Proper installation, maintenance and operation procedures must be observed. The instructions given above must be followed. Inspections should be made as necessary to assure safe operation under prevailing conditions. All rotating power transmission products when used in a drive are potentially dangerous and must be guarded by the user as required by applicable laws, regulations, standards, and good safety practice. (Refer to ANSI Standard B15.1.)